

JACK RABBIT

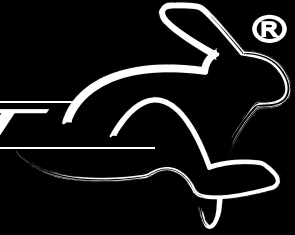

RETRACTABLE HARD TRUCK BED COVERS

FRONTIER CREW CAB XSB INSTALLATION INSTRUCTIONS



#1 RETRACTABLE TRUCK BED COVER

(800) 338-3697
www.paceedwards.com

Pace Edwards Company
2400 Commercial Blvd.
Centralia WA 98531

TABLE OF CONTENTS

Tools Required for Assembly.....	2
Before You Start	2
Drain Hole Locations	2
Packaging Contents	2
STEP 1: Positioning Canister	3
STEP 2: Install & Fasten Rails	3
STEP 3: Fasten Canister.....	4
STEP 4: Lubricating & Placing Sweep Seals	4
STEP 5: Assembling Pull Strap & Handle	5
STEP 6: Installing Drain Tubes.....	6
STEP 7: Install Top Cover & Velcro to Pull Strap ..	6
Operating Instructions	7
Helpful Maintenance Hints	7
Warranty Statement.....	8

Part #: JR-FCC-INSTALL 056
CANISTER PART # TR2037

TOOLS REQUIRED FOR ASSEMBLY:

7/16" wrench or socket
7/8" socket, ratchet
3/32" Allen wrench
#2 Philips screwdriver
Wire cutters
#30 Tork Bit

Pliers for spring clip
Threadlocking adhesive (such as Henkel's *Loctite*®)
UV Protectant or Petroleum-based lubricant
Rag

Note: There should be no drilling into the truck body needed but the drain tube holes may need to be made larger.

BEFORE YOU START:

Read the instructions carefully before you start. These instructions are written for one-person installation. We have noted where briefly having an extra person's assistance can make installation easier. If you have questions regarding the installation please call our Technical Support Line at (800) 338-3697.

DRAIN HOLE LOCATIONS:

The JackRabbit is designed to carry rainwater from the cover into the canister and then out through the drains. Most truck models have standard OE drain holes or plastic/rubber access ports in the front of the truck bed. Check to make sure your truck has the OE drain holes so that drilling into the sheet metal is not required. If drilling is necessary, be sure to check the underside of the truck bed for the best location. The holes should be located near the side and as far forward as possible. Use a drill bit suitable for sheet metal (such as a taper drill or step drill). Drill drain tube clearance holes at 3/4" (19mm). This will need to be done before installing the cover.

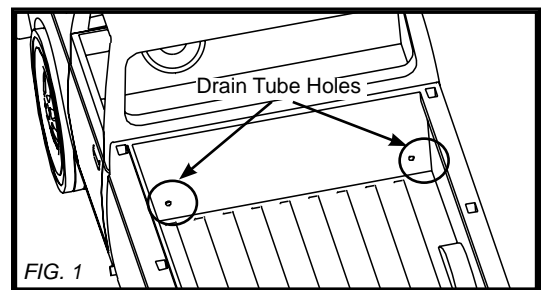

CAUTION!

DO NOT USE A KNIFE TO OPEN THE RAIL BOX. OPEN THE RAIL BOX ALONG THE LENGTH OF THE BOX AND LIFT RAILS OUT TO AVOID SCRATCHING THE SURFACE OF THE RAILS ON THE PACKAGE STAPLES.

CAUTION!

PACKAGING CONTENTS:

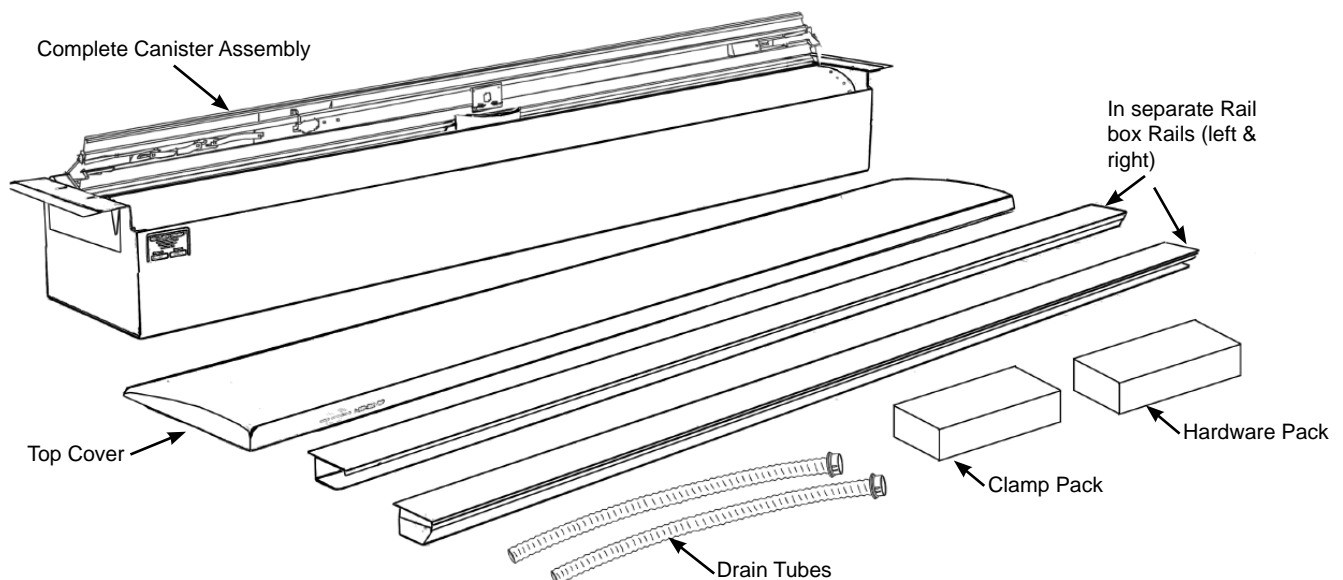

STEP 1: POSITIONING CANISTER

Using the 30# Tork Bit remove the front UtiliRack rail (closest to the truck cab) from the truck bed.

Remove the top cover from the canister box and set it aside for later installation. Perform a quick inventory to insure all parts are there. Be sure to check inside the small cardboard box for parts.

Remove the Canister from the box and set it in the truck bed against the cab. The canister should be resting on the canister end plates and be centered in the truck bed. (Fig. 1)

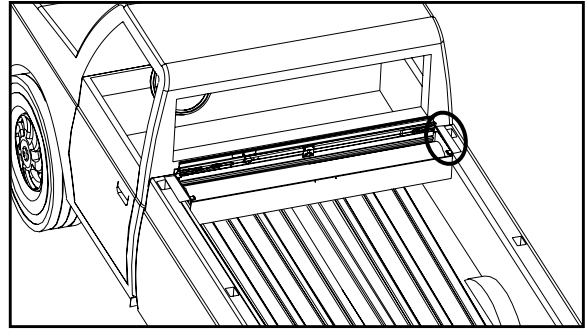

INSTALL TIP!

TO MAKE RAIL INSTALLATION EASIER YOU MAY WANT TO HAVE ANOTHER PERSON HOLD THE RAILS IN PLACE WHILE YOU ARE TIGHTENING THE CLAMPS. YOU CAN ALSO TEMPORARILY TAPE THE RAILS IN PLACE WHILE TIGHTENING THE CLAMPS IF ANOTHER PERSON IS NOT AVAILABLE.

INSTALL TIP!

STEP 2: INSTALL & FASTEN THE RAILS

HARDWARE USED:

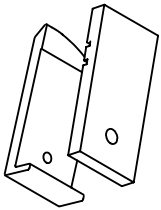

OUTER & INNER RAIL CLAMPS x 4



1/4" FLAT WASHER x 4



1/4" LOCK WASHER x 4



RAIL CLAMP BOLT x 4

Open the rail box along the length of the box; lift rails out to avoid scratching the rail surface on the package staples.

The side rails are marked "left" and "right" (left is the driver's side of the truck). With the tailgate closed, place the side rails in position on the truck bed. Side rails have a rubber spacer on the end caps, at the tailgate end, to establish the correct spacing to the tailgate (1/16") and to prevent the tailgate from striking the side rails when closing. Press the rail tightly against the closed tailgate.

Place the four (4) clamps over the brackets located on the underside of the rails.

Locate the top groove of the inner clamp bracket onto the lip of the rail bracket (as shown Fig. 2).

Rotate the outer clamp bracket clockwise to tighten rail downward against bed rail.

Apply downward pressure while tightening the clamps on the rails, especially on the tailgate end. This will ensure a tight seal, firm seat, and good fit on the truck bed.

Tighten bolt securely. (*Adjust pressure against tailgate by moving rails forward or backward as needed prior to final tightening of clamps.*)

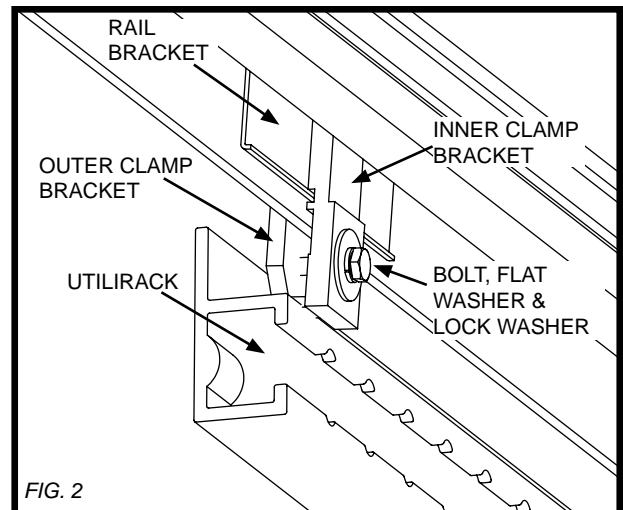
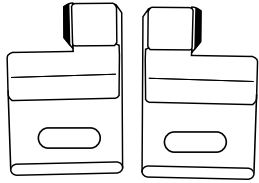

FIG. 2

DO NOT TIGHTEN OVER 120-INCH POUNDS!

STEP 3: FASTEN CANISTER

HARDWARE USED:



RAIL STOP (LEFT & RIGHT)



RAIL STOP BOLT
(1/4-20 x 3/4") x 2



3/16" FLAT WASHER x 2



1/4" LOCK WASHER x 2

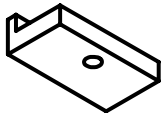

CANISTER CLAMP x 2

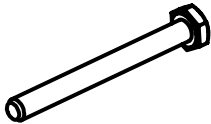

CLAMP BOLT
(1/4-20 x 2 3/4") x 2



CLAMP WASHER x 2

Slide canister against the front cab sill of the bed so that the canister and rails rest firmly on the sides of the truck bed.

Slide the rail stops on the rail up to the canister.

Position the rail stops snug up against the canister. Then use the 1/4"-20 x 3/4" hex bolt, 3/16" flat washer and 1/4" lock washer to tighten the rail stops in place, utilizing the existing threaded hole on the underside of the rail.

Center the canister side-to-side on the truck bed and fasten it in place with the canister clamps.

Use one clamp per side of canister. Install 1/4" - 20 x 2 3/4" bolt with fender washer through one of the slots in each end of the canister and attach the Canister Clamp. (Figure 3)

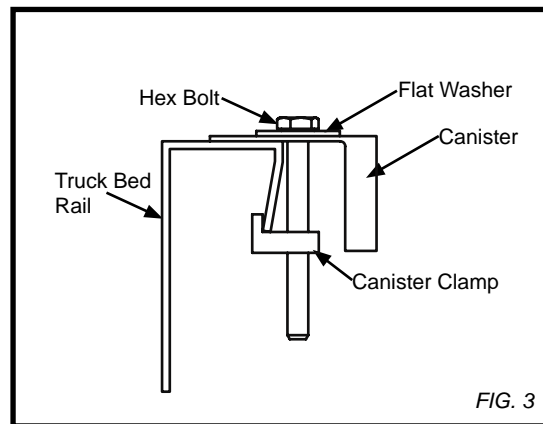

FIG. 3

STEP 4: LUBRICATING & PLACING THE SWEEP SEALS

Locate the sweep seals (rubber weather strips) on the rails. Apply Pace Edwards' UV Protectant (or 303 brand protectant) to a rag and wipe the underside of the sweep seal and the top of the wear strip.

Carefully remove the ZIP tie securing the cover to the canister we recommend using the wire cutters for this. Roll the handle down into the ends of the rails and down to the tailgate. Using an Allen wrench (if necessary) to carefully draw out the sweep seal (seal should be angled outwards toward the cover – not rolled in toward the bed rail).(Figure 4)

Proper care and placement of the sweep seal will ensure smooth operation of the cover. Remove the protective foam cover from the underside of the fabric panel. Remove the protective film from the inside back of the canister.

DO NOT ALLOW THE HANDLE TO ROLL INTO THE CANISTER AS PERMANENT DAMAGE MAY OCCUR TO THE FABRIC.

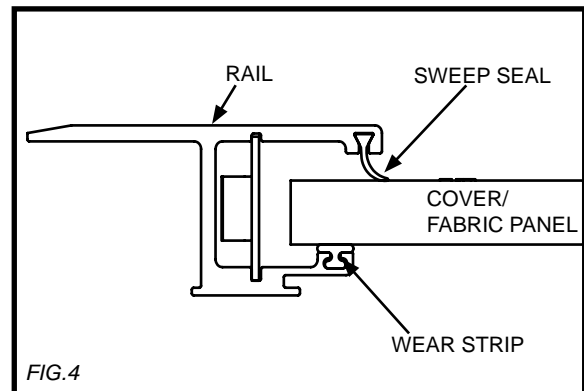

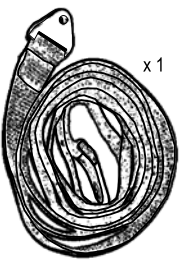



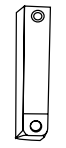





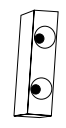

FIG.4



PERMANENT DAMAGE MAY BE CAUSED IF THE HANDLE ASSEMBLY IS ALLOWED TO RETRACT INTO THE CANISTER WITHOUT PROTECTION ON THE UNDERSIDE OF THE FABRIC PANEL!

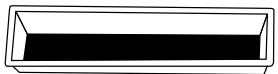

STEP 5: ASSEMBLING PULL STRAP AND HANDLE

Pull Strap  x 1	Hex Bolt (1/4"-20 x 5/8")  x 1	1/4" Flat Washer  x 2	Pull Strap Screw (8-32 x 3/4")  x 1	Handle Stop  x 2	Handle Stop Screw (8-32 x 3/4" pan head)  x 4	Lock Cylinder  x 1	Lock Cylinder Nut  x 1
	Lock Cylinder Screw & Spider Nut  x 1	Lock Tab  x 1	Lock Keys 	Lock Link Block  x 1	Lock Link Block Screw (8-32 x 3/4" flat head)  x 2	Hand Grip  x 1	

Install 1/4-20 x 5/8" hex bolt, 1/4" flat washer and handle end of pull strap into the center block on the handle (we recommend that you use a threadlocking adhesive such as Loctite® on the pull strap bolt).

Install the tailgate end of the pull strap to the underside of the drivers side rail using the #8-32 x 3/4 machine screw located at the tailgate end on the underside of the rail. (Figure 5A)

Install the handle stops onto the underside of the handle using #8-32x3/4" pan head screws and insert the lock cylinder into the lock hole on the handle.

Tighten the lock cylinder nut using a 7/8" socket wrench.

Install the lock tab onto the lock cylinder with the lock cylinder screw and 1/4" spider lock washer so the tab points to the passenger side of the truck.

Next, install the lock link block under the handle with (2 ea) #8-32x3/4" flat head screws.

Insert the handgrip into the handle cutout so that the angled side is towards the truck cab then pull back to snap the handle into place.

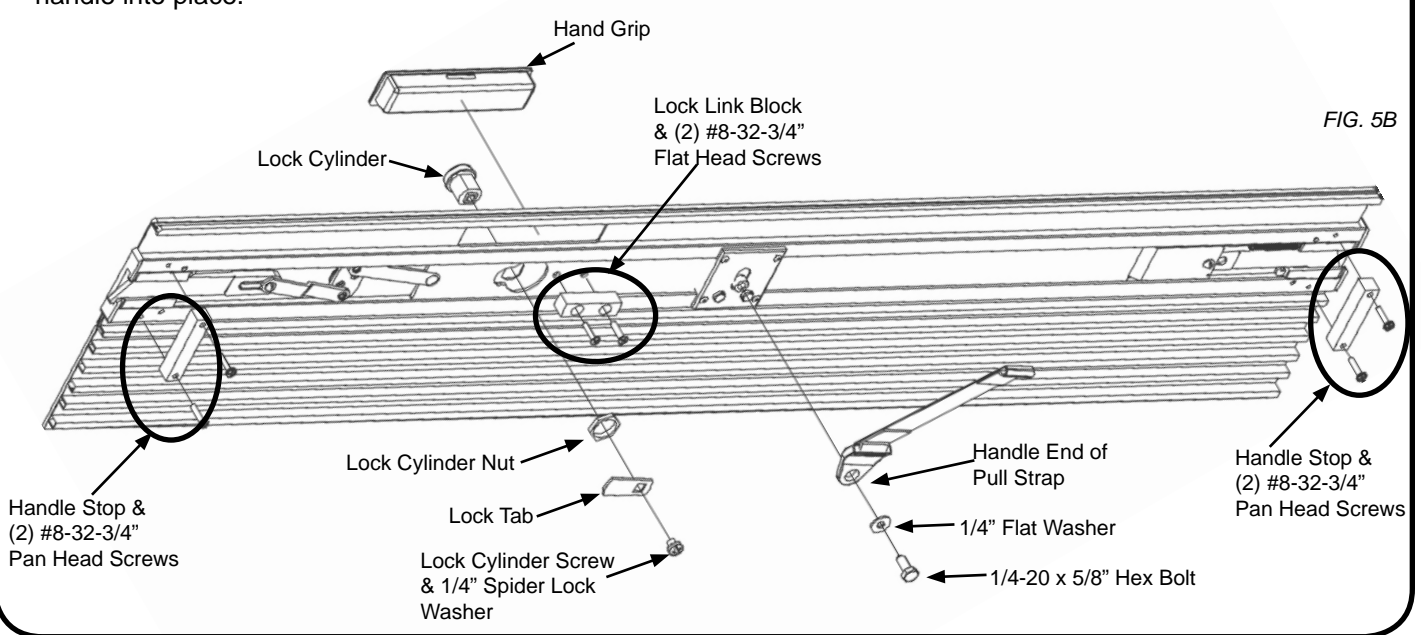
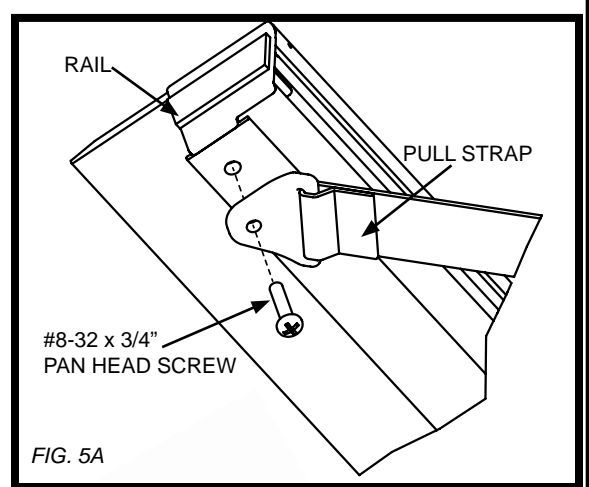

STEP 6: INSTALLING DRAIN TUBES

First ensure that the "o" ring is in place on the drain tube end being inserted into the canister (This will prevent water leakage).

With the cover *opened*, insert the drain tube fittings into the pre-drilled holes on the underside of the canister by pushing them in place from under the canister. Drain tube should click into place.

Place the other end of the drain tube through the grommet or through the pre-drilled holes in the floor or the front wall of the truck bed.

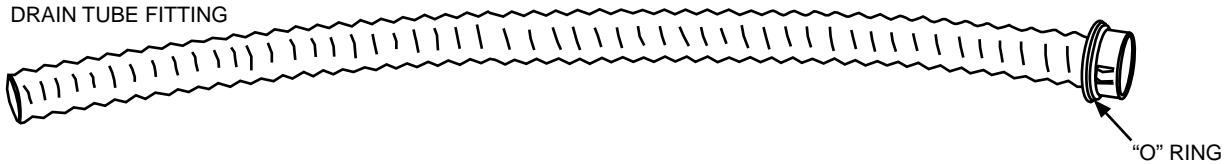

STEP 7: ATTACHING TOP COVER & VELCRO TO PULL STRAP

HARDWARE USED:



4' VELCRO STRIP



BLACK TOP COVER
SCREW x 2



PLASTIC CANISTER
INSERT x 2

Insert the plastic canister inserts into the square holes located on either side of the canister.

Place the Top Cover on the canister and install with the four long Top Cover screws.

Tighten the screws until the cover is just touching the truck bed. Be sure the high side showing the label faces the tailgate. **Do not over tighten.**

Retract the cover to the fully open position.

Attach the 4" Velcro strip onto the Velcro strip already attached to the pull strap.

Pull the pull strap over to the driver's side rail and remove the tape from the 4" Velcro strip.

Then apply the Velcro strip onto the underside of the rail at your desired position.

This will hold the pull strap off of the floor and out of the way when cargo is being stored in the truck bed.

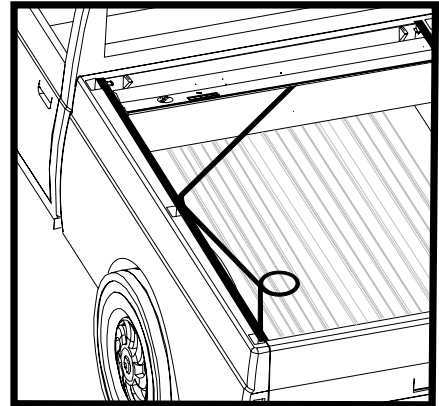

You have now completed the installation of your JackRabbit Series hard tonneau cover. If you have any questions please do not hesitate to call us at: (800) 338-3697 and ask for our technical service department.

OPERATING INSTRUCTIONS

1. To open the cover, turn the actuator knob clockwise 90° until it clicks in the open position. This retracts the latches into the handle and the cover is free to roll open into the canister. A tug on the pull strap will release the latch and allow the cover to lock into the rails.
2. To latch the cover in one of the mid-range positions, pull it back just beyond the position desired and allow the cover to retract until it latches into place. Latching positions are located every 12 inches along the rails. The clicking sound is the spring-loaded latches mounted inside the handle. The latches are designed to bypass the latching positions as the cover is being closed and to stop the cover as it is being retracted.
3. To close the cover, pull on the strap to draw it back toward the tailgate. When it is within easy reach, grasp the handle by the hand grip and pull the cover to the latching position against the tailgate.
4. To use the key lock, position the cover on the truck bed with the actuator knob in the closed position and turn the key.

HELPFUL MAINTENANCE HINTS

To assure quiet, smooth operation, apply a small amount of Pace Edwards' UV Protectant (or 303 brand lubricant) to a rag and wipe the underside of the sweep seal and the top of the wear strip. Re-apply if the cover begins squeaking or sticking during use. (Fig. 1)

Proper care and placement of the sweep seal will ensure smooth operation of the cover. Alcohol, petroleum based or silicon-based cleaners such as Armor-All® should be avoided and ARE NOT recommended for our covers.

Periodically remove the Top Cover and clean out the canister.

It is important to open and close the cover regularly; the spring that operates the cover is self-lubricated and regular use assures that it stays in proper working condition.

Drain tubes may become clogged overtime and should be removed and cleaned. To remove the drain tubes you must; Remove the Top Cover, close the cover to the tailgate, reach in the canister and depress the plastic retaining tabs on the drain tube fittings and push the drain tube out of the hole in the bottom of the canister. (Fig. 2)

To help keep the JackRabbit tonneau cover looking it's best, we recommend washing it the same as caring for your truck finish. However you should not wax your cover. Using a citrus-based vinyl cleaner and protectant such as Pace Edwards Brand or the 303 brand will keep your cover looking like new. Alcohol, petroleum based or silicon-based cleaners such as Armor-All should be avoided and ARE NOT recommended for our covers.

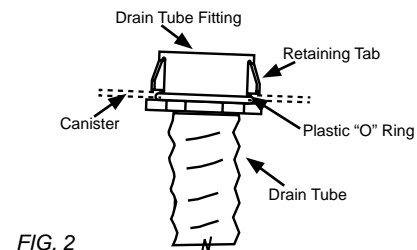
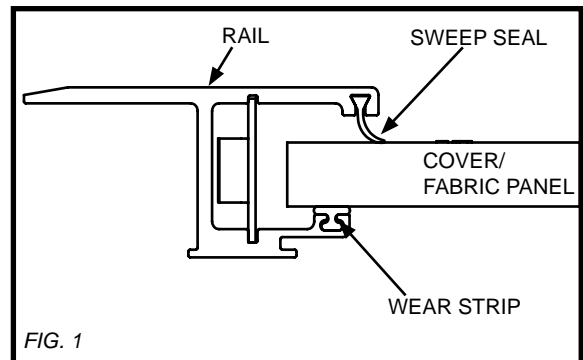

CONGRATULATIONS!

On your purchase of a Pace Edwards Retractable Truck Bed Cover. We are confident that you will get many years of trouble free service from this accessory to your truck. Please take a moment to fill out the warranty registration form to activate warranty coverage of your truck bed cover.

PACE EDWARDS PRODUCT WARRANTY

PACE EDWARDS (hereinafter referred to as the MFG.) warrants each new Pace Edwards Bedlocker®, JackRabbit®, Full-Metal-JackRabbit™, and Roll-Top-Cover® retractable truck bed cover to the original owner as follows:

FOR A PERIOD OF THREE (3) YEARS FROM THE DATE THE UNIT IS DELIVERED TO THE FIRST PURCHASER OR PLACED INTO SERVICE AS A DEMONSTRATOR OR COMPANY UNIT:

- Delamination of the ArmorTek deck
- Separation of the Bedlocker/Full Metal deck panels
- Failure of the Continuous Tension Spring
- Failure of the Bedlocker drive system
- All lock assemblies
- All hardware and components

ITEMS NOT COVERED UNDER WARRANTY FOR ANY PERIOD OF TIME:

- Rips, tears, or discoloration of the ArmorTek deck material
- Seals and gaskets
- Water intrusion from any source
- Dealer and/or purchaser installed parts and accessories

CERTAIN CONDITIONS WILL VOID ALL WARRANTY.

These conditions include:

- Use for any purpose other than normal private use including rental and promotion
- Altering the retractable truck bed cover in any manner without written approval of the MFG
- Misuse, negligence or accident
- Installation of any part or accessory without written approval from the MFG
- Failure to register this warranty with the MFG within fourteen (14) days from date of delivery

CLAIM PROCEDURE

If a part fails, the purchaser should return to the selling dealer to determine if the failed part is covered under the terms of this warranty. If a Warranty Claim is necessary, the dealer will contact Pace Edwards to obtain A Return Goods Authorization. If it is impractical for the purchaser to return to the selling dealer, then the purchaser may contact the Pace Edwards Technical Assistance Help Desk at 1-800-338-3697 to determine warranty eligibility. In either event, it is the responsibility of the purchaser to obtain a Return Goods Authorization prior to returning the defective part to the MFG. The defective part, along with a copy of the original Bill of Sale and the Pace Edwards issued RGA #, must be returned PREPAID to Pace Edwards Co. 2400 Commercial Blvd. Centralia, WA 98531. After determining the validity of the warranty claim, PACE EDWARDS will ship a replacement part prepaid to the customer. Labor costs to replace defective parts are the responsibility of the purchaser.

CONDITIONS AND LIMITATIONS

This warranty is subject to certain conditions and limitations including, but not limited to, the following:

- Any part of a Pace Edwards retractable truck bed cover that is found to be defective under the terms of this warranty will be repaired or replaced using either new or reconditioned parts at the discretion of the MFG.
- In determining what constitutes a failure under the terms of this warranty the decision of the MFG shall be final.
- This warranty is extended to the original purchaser only and is not transferable to subsequent purchasers.
- The MFG does not accept any responsibility in connection with the installation of any of its products by its dealers or agents.
- The MFG does not undertake responsibility to any purchaser for warranty express or implied by any of its dealers, distributors or agents beyond that which is contained herein.
- Without regard to an alleged defect of its products the MFG under any circumstances does not assume responsibility for loss of time, inconvenience, revenue, or other consequential damage including, but not limited to, expenses for telephone, food, lodging, travel, loss or damage to the vehicle the products are installed on or loss or damage to personal property of the purchaser or user of the products.
- The MFG reserves the right to make changes in the design of, improvements to, or warranty of its products without imposing any obligation upon itself to provide the same for any products theretofore manufactured.

Some jurisdictions do not allow limitations on or exclusions to warranties, therefore some of the exclusions may not apply to you. This warranty affords you specific legal rights. You may have other legal rights that may vary from jurisdiction to jurisdiction.

WARRANTY REGISTRATION

Please return this completed warranty registration within 14-days to:
Or go online and register your warranty at: www.paceedwards.com/reg.asp

**Pace Edwards
Attn: Warranty Dept.
2400 Commercial Blvd.
Centralia, WA 98531**



NAME: _____

ADDRESS: _____

CITY: _____ PROV./STATE: _____ PC/ZIP: _____

MODEL #: _____ SERIAL #: _____

DATE OF PURCHASE: _____ PURCHASED FROM: _____ PRICE PAID: _____

CUSTOMER SIGNATURE: _____